

# Vernier Caliper

## SERIES 531 — with Thumb Clamp

### FEATURES

- The slider moves only when the spring loaded thumb clamp is depressed.
- Can measure OD, ID, depth, and steps
- Supplied with vinyl holster in fitted carton.

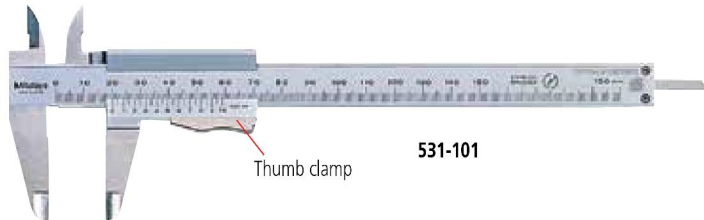

### SPECIFICATIONS

#### Metric

Range	Order No.	Accuracy	Graduation	Remarks
0 - 150mm	<b>531-101</b>	±0.05mm	0.05mm	—
0 - 200mm	<b>531-102</b>	±0.05mm	0.05mm	—
0 - 300mm	<b>531-103</b>	±0.08mm	0.05mm	—

#### Metric/Inch with metric/inch dual scale

Range	Order No.	Accuracy	Graduation		Remarks
			Lower Scale	Upper Scale	
0 - 150mm / 0 - 6"	<b>531-122</b>	±0.05mm	0.05mm	1/128"	with inch/mm conversion label
0 - 150mm / 0 - 6"	<b>531-128</b>	±0.03mm	0.02mm	.001"	High accuracy model
0 - 200mm / 0 - 8"	<b>531-108</b>	±0.05mm	0.05mm	1/128"	—
0 - 200mm / 0 - 8"	<b>531-129</b>	±0.03mm	0.02mm	.001"	High accuracy model
0 - 300mm / 0 - 12"	<b>531-109</b>	±0.08mm	0.05mm	1/128"	—
0 - 300mm / 0 - 12"	<b>531-112</b>	±0.04mm	0.02mm	.001"	High accuracy model

### DIMENSIONS AND MASS

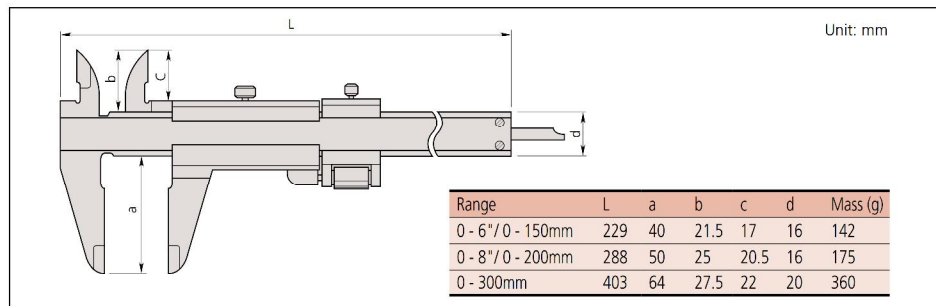

### "Quadri" (4 way) Measurement Measurement Applications

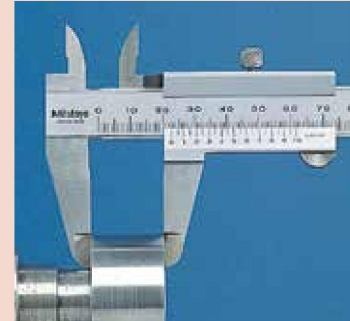

OD measurement

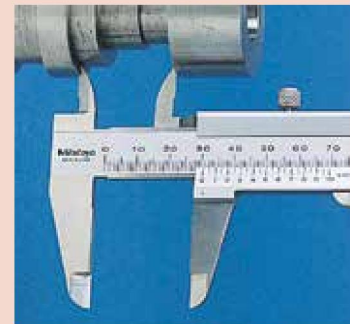

ID measurement

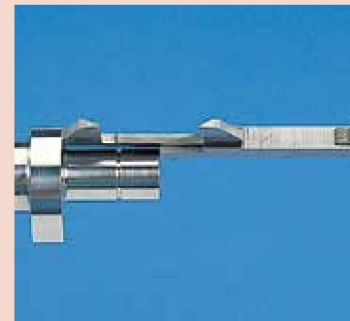

Step measurement



Depth measurement